



永安机械
YONGAN MACHINERY

EXCAVATOR
MOUNTED
VIBRATORY
HAMMER

挖掘机振动打桩锤

已通过ISO9001国际质量管理体系认证
CERTIFIED BY ISO9001 INTERNATIONAL QUALITY MANAGEMENT SYSTEM

产品结构

MAIN STRUCTURE



360度转盘
360degree Rotation Gear Box



固定架
Mounting Bracket



通气口
Air Vent



减震胶
Elastomer



主机液压马达和齿轮箱
Vibrating Motor and
Vibrating gear box





液压油路系统
Hydraulic Oil System

电路控制盒
Circuitry Control Box



180度可翻转吊臂
180degree
Rotation Arm



控制手柄
Control Handle



液压夹具
Hydraulic Clamps



施工实图

APPLICATION



Sandy soil
I beam 8m
30T excavator
V-300C vibro hammer
C16 clamp
A250 vice arm.
砂土层，8米工字钢，30吨挖掘机，
V-300C打桩机，C16夹具，
A250副手臂。

Sandy soil
Concrete pile 9m
36T excavator
V-350C vibro hammer
C32 clamp
A250 vice arm.
砂土层，9米水泥桩，36吨挖掘机，
V-350C打桩机，特制C32夹具
A250副手臂。



Clay soil
Channel steel 6m.
20T excavator
V-250D vibro hammer
C15 clamp
A200 vice arm.
粘土层，6米槽钢，20吨挖掘机，
V-250D打桩机，C15夹具，
A200副手臂。

Sandy soil
Drilling
20T Excavator
V-300C vibro hammer
C16 clamp.
砂土层，冲孔，20吨挖掘机，
V-300C打桩机，C16夹具。



Sandy soil
Lassen Pile 12m
40T excavator
V-350C vibro hammer
C18 clamp
A300 vice arm.
砂土层，12米拉森桩，40吨挖掘机，
V-350C打桩机，C18夹具，A300副手臂。

技术参数

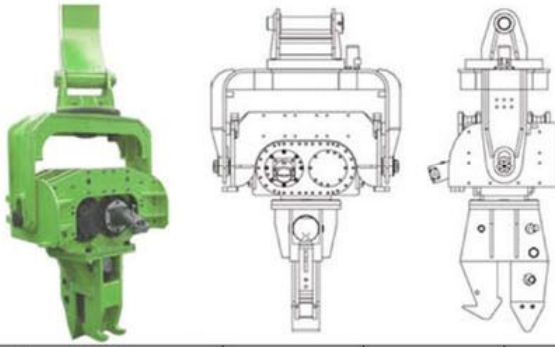

TECHNICAL DATA

Data/Model 项目	V-250D	V-300C	V-330C	V-350C	V-400C	V-450A	V-500A
Eccentric moment(Kg.m) 偏心力矩	5	6	6.5	7	8	8.5	13
Frequency(rpm) 转速	2400	2400	2400	2400	2400	2400	2400
Centrifugal force(t) 激振力	33	38	42	45	50	55	> 60
Hydraulic system operation pressure(bar) 液压系统操作压力	280	300	300	300	300	300	300
Hydraulic system oil flow(lpm) 液压系统流量需求	132	181	209	209	258	258	386
Weight(kg) (excluding clamp and vice arm) 主机重量	1550	1650	1650	1800	2000	2050	2100
Excavator Weight(t) 适用挖掘机重量	20~25	25~30	30~35	30~40	40~45	45~50	> 60
Size(mm) (measured with C16 clamp) 尺寸(测量时以C16夹具为例)	880*1245*2235	880*1245*2235	880*1245*2235	980*1255*2320	980*1460*2340	980*1460*2340	980*1460*2340
Clamp model/ weight(kg) 夹具型号/重量	C12/300KG; C11B/360KG; C15/455KG; C16/500KG; C30B/455KG						
Vice arm Model/Weight(kg) 副臂型号/重量	A150/450KG; A200/550KG; A250/600KG; A300/750KG; A350/900KG						

夹具 CLAMPS



C15 suitable for channel steel, sheet pile, small pipe
C15 适用于槽钢、钢板、小型钢管
C16 suitable for Lassen pile, I beam
C16 适用于拉森桩、工字钢
C18 suitable for Lassen pile, I beam
C18 适用于拉森桩、工字钢

C12G specially for small pipe
C12G 适用于小型钢管桩
C30B suitable for square concrete pile, custom designed
C30B 适用于混凝土方桩，可依据客户需求定制
C30C suitable for round concrete pile, custom designed
C30C 适用于混凝土圆桩，可依据客户需求定制

副手臂 VICE ARMS

1.5m, 2.0m, 2.5m, 3.0m, 3.5m
vice arms are available.
各种尺寸副手臂可供选择。



产品特性

MAIN FEATURES

多种型号，适配于不同挖掘机

从V-200到V-500,七种不同型号的挖机锤适配于20到60吨的挖掘机。

ADOPTABLE CARRIERS

V-250,300,330,400,450,500 are built and designed for excavators weighting from 20 tons to 60 tons.

应用范围广

V系列挖掘锤体型小，操作简单，可广泛应用于各种施工环境，例如维护排污系统，加固河岸，湿地作业等陆地和浅水工况。

A WIDE RANGE OF CONSTRUCTIONAL AREAS

Because of its small size and simple operation procedure, it can be applied for a wide range of working environment: such as drainage maintenance, river-bank maintenance and marshland working wherever onshore and offshore piling job.



水泥桩 Concrete pile



钢板桩 Sheet pile



木桩 Wooden pile

360度可旋转机身

安装有可旋转的支架，使得挖机锤能在工作中360度自由旋转。锤头还能够调整到平行于地面的位置倒地夹桩。

360° ROTATION FUNCTIONING

Excavator mounted Vibratory Hammers are equipped with a rotating mounting bracket that allows the Vibratory Hammer to rotate 360 degrees. Therefore the body will be paralleled with the ground and makes it easy to clamp onto and lift sheets from the ground.



进口机械减震胶

机械减震胶能够通过自身的伸缩有效地缓冲振动。它能至少够为挖掘机和操作人员减去90%的振动。

QUALIFIED ELASTOMERS

Mechanical Stops Prevent Elastomers which take a role as a shock absorber from stretching during operation.

Elastomers provide a minimum 90% of vibration isolation for equipment and personal safety.



简单的设计

由于采用了简单的结构设计，V系列挖掘锤的操作和保养都非常简便。可以实施遥控操作。

SIMPLE DESIGN

The adoption of simple design principle allows easy maintenance and prompt trouble shooting for operators both on control and mechanical side. Together easy operation can be obtained using Friendly design of remote control device.



工作原理

WORKING PRINCIPLE

1. 无需额外动力装置，完全依靠挖掘机固有的液压系统供给动力。

1.No necessary of additional power pack and power unit and just pick up the hydraulic supply from existed excavator supply line.

2. V系列液压振动打桩锤桩机内置两只偏心轴，采用液压马达驱动，产生高速旋转及垂直激振力，透过减震橡胶块后，维持一定振幅，能够适应各类型土质与打桩要求。

2.With two eccentric shafts inside, driven by hydraulic motor, it offers high-speed rotation and vertical centrifugal force. Through the Elastomers, the hammer vibrates with certain amplitude, thus it could be applied for different soil conditions and piles.

3. V系列挖掘锤是利用其高频振动，以高加速振动桩身，将机械产生的垂直振动传给桩体，导致桩周围的土壤共振并液化，从而减少桩侧与土体的摩擦力。

3. V-series excavator mounted vibro hammer is high frequency hydraulic vibratory hammer. It delivers its high frequency vertical vibration to the pile. When the pile vibratory frequency is consistent with the soil's, the soil will occur resonance phenomenon. In that case the pile will disintegrate from the soil in a short time. Pile sinking resistance will be reduced very quickly.



福建新永安机械有限公司
Fujian New Yongan Machinery Co., Ltd.

地址：福建省福鼎市贯岭工业区
电话：86- 593- 7260222
传真：86- 593- 7260222
Add:Guanling Industrial Zone, Fuding, Fujian, China
Office Tel: +86-593-7260222
Office Fax: +86-593-7260222

瑞安市永安机械有限公司
Ruian Yongan Machinery Co., Ltd.

地址：瑞安市塘下镇海安海阳工业区青岙山头88号
电话：86-577-65278666
传真：86-577-65271769
Add:No.88 Qingao, Haiyang Industrial Zone, Tangxia, Ruian, China
Office Tel: +86-577-65278666
Office Fax: +86-577-65271769

上海永安机械设备有限公司
Shanghai Yongan Machinery Co., Ltd.

地址：上海市闸北区南山路100号139室
电话：86- 21- 33197093
传真：86- 21- 33250313
Add:Room 139, No.100 Nanshan Road,200070, Shanghai, China
Office Tel: +86-21- 33197093
Office Fax: +86-21- 33250313